

LEISTER Astro Automatic Wedge Welding Machine



Please read operating instructions carefully before use and keep it for further reference.

APPLICATION

The LEISTER Astro is an automatic wedge-welding machine for overlap welding of geomembrane liners in earthwork and civil engineering.

• Thermoplastic geomembrane liners

High-density polyethylene	PE-HD
Low density polyethylene	PE-LD
Chlorinated polyethylene	PE-C
Polypropylene	PP

• Type of seam

Welding seams are produced in accordance with DVS 2225 part I
Other dimensions are possible on request.

DVS: German Welding Society for welding





WARNING



Danger! Unplug the tool before opening it as live components and connections are exposed.



Incorrect use of the hot wedge tool can present a **fire and explosion hazard** especially near combustible materials and explosive gases.



Do not touch the element housing and wedge when hot as they can cause **burns**. Allow the tool to cool down. Do not point the hot air flow in the direction of people or animals.



Connect the tool to a **socket outlet with protective earth conductor**. Any interruption of the protective earth conductor within or outside the tool is dangerous! **Use only extensions cables with a protective earth conductor!**



CAUTION



The **voltage rating** stated on the tool should correspond to the mains voltage.



For personal protection, we strongly recommend the tool be connected to an **RCCB (Residual Current Circuit Breaker)** before using it on construction sites.



The tool **must be operated** under supervision. Radiant heat from the hot wedge can ignite flammable materials.



Protect the tool from **damp and wet**.

APPROVAL MARKS



TECHNICAL DATA

Protection class I  **CCA** certified

Voltage	V~	120, 200, 230 ★	★ mains voltage is not reversible
Frequency	Hz	50 / 60	
Power consumption	W	1800	
Temperature	°C/°F	max. 420/788	
Welding pressure	N/lbs	max. 1500/337	
Drive	m/min./feet	0,8–5,0/2.6 - 16.5	
Overlap width	mm/Inch	max. 150/5.9	
Thickness of material	mm/mil	1,5 – 3,0/60 - 120	
Size L×W×H	mm	475 × 355 × 315 with carrying handle / guide handle (12)	
Weight	kg/lbs	23/50	

- **Heating system** → The hot air temperature is steplessly adjustable and electronically controlled. It is a floating hot wedge.

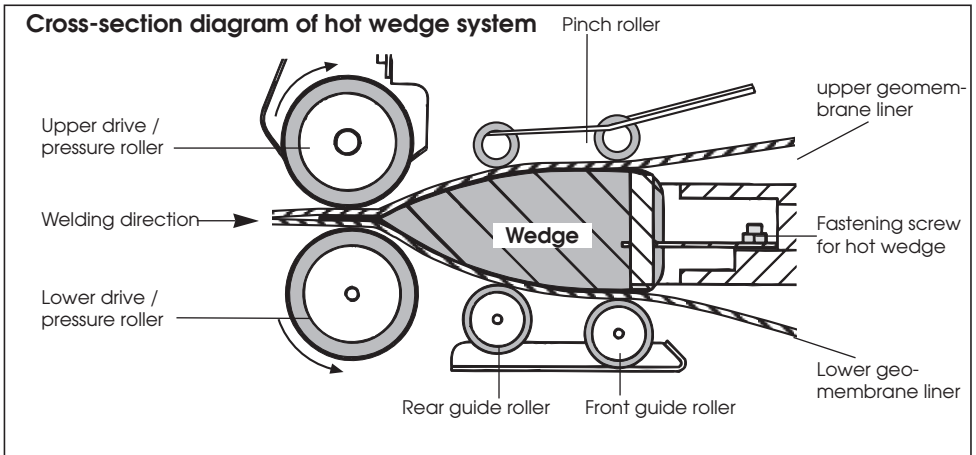

- **Welding pressure** → infinitely variable (steplessly adjustable). The welding pressure is transmitted via a toggle lever to the pressure rollers. The **swivel head guarantees the equalization of the pressure to both** welded sections (C and D) as well as on a welded seam without test channel. This allows T-joints to be welded easily. During the welding process the pressure adjusts itself linearly to the change in material thickness of the geomembrane liners.

Cross sectional diagram of an overlap weld

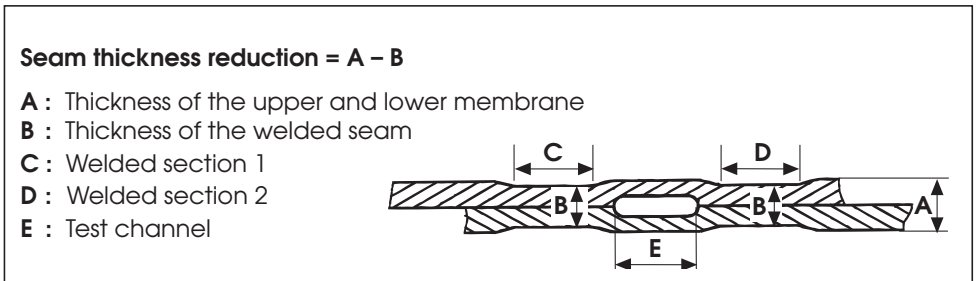

- **Drive** → The welding speed is adjustable and electronically controlled in steps of 0.1 m/min / feet. Digital display of SET and ACTUAL values. The power transmission works through a **three stage planetary gear**.

Frontal view

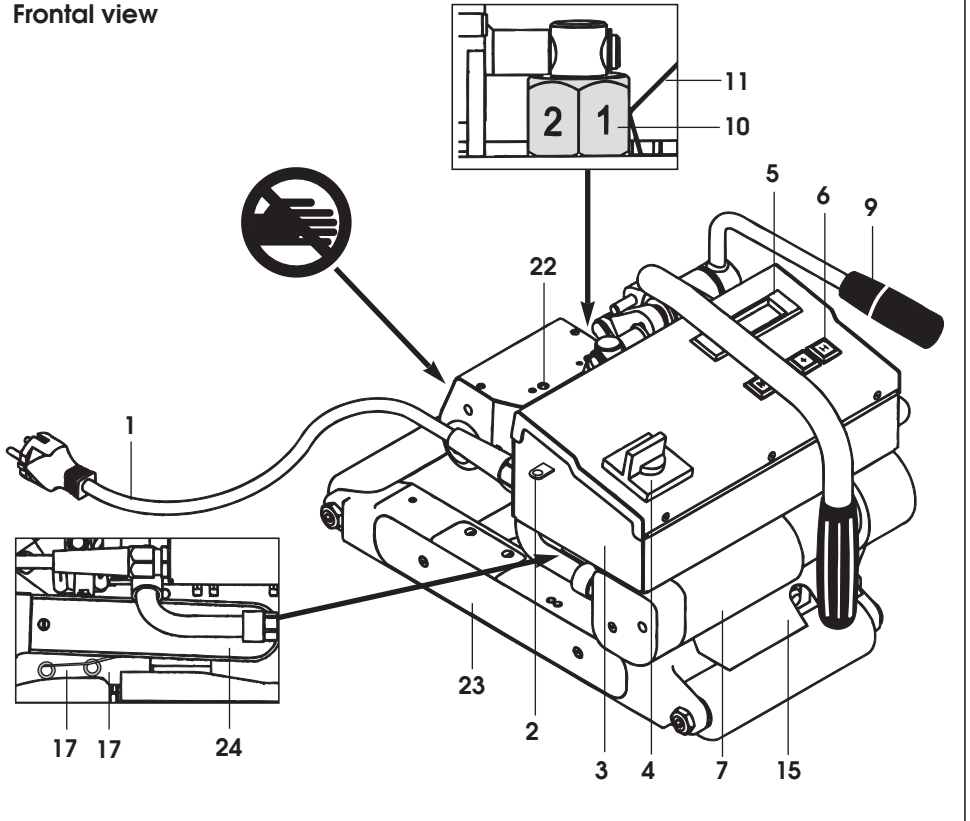

Side view

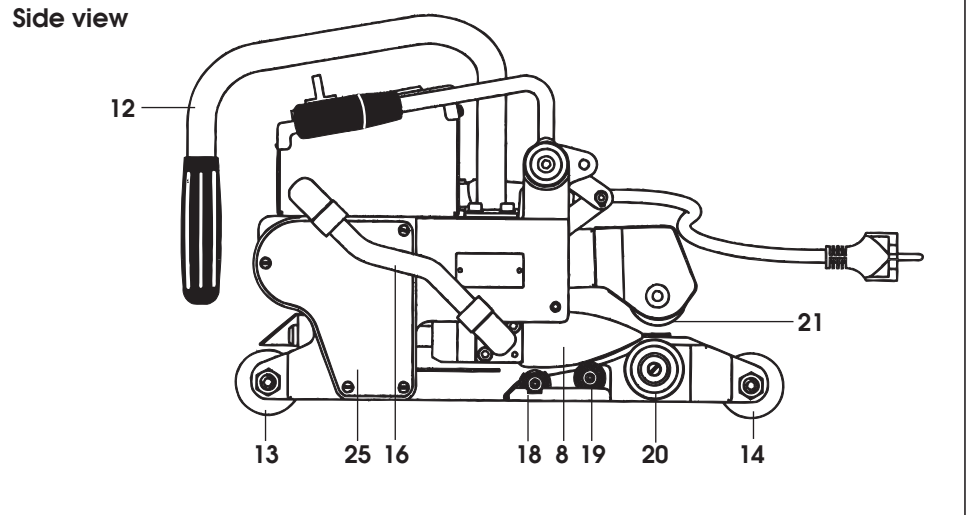

1. Mains cable
2. Cable clip
3. Housing of electronics
4. Main switch
5. Display
6. Keyboard
7. Motor/ Drive
8. Hot wedge
9. Lever
10. Adjustment screw for welding pressure
11. Locking spring of adjustment screw
12. Carrying handle / Guide handle
13. Front wheel
14. Back wheel
15. Foil guide
16. Cable conduit for hot wedge
17. Pinch roller
18. Front guide roller
19. Rear guide roller
20. Lower drive/pressure roller
21. Upper drive/pressure roller
22. Adjustment screw for swivel head
23. Chain guard of lower part
24. Chain guard of tension arm
25. Chain guard of gear case

WELDING PARAMETER

LEISTER Astro

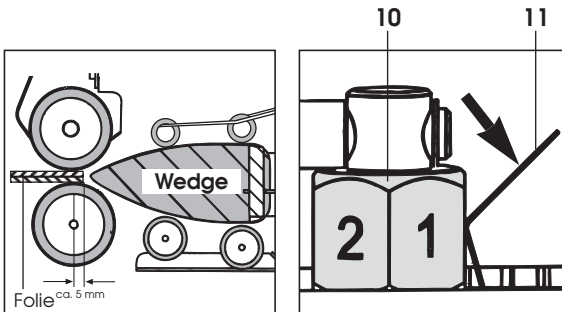

Welding pressure

Engage and position the automatic welding machine onto the material to be welded. Insert the two geomembranes liners or films about 5mm at the back of the machine. Pull the **lever (9)**. The hot wedge is automatically pushed forward. Push and hold down the **locking spring (11)**. Turn the adjustment screw for **welding pressure (10)** until the **drive/pressure rollers (20/21)** slightly touch the material to be welded. Let go the **locking spring (11)** and release the tension of the **lever (9)**.

Keep pushing the locking spring of the **adjustment screw (11)**. Adjust the welding pressure by turning the corresponding **adjustment screw (10)** according to illustration A and let go the **locking spring (11)** at the requested welding pressure.

Warning:

If the maximum welding pressure of 1500N is exceeded mechanical damage may occur.

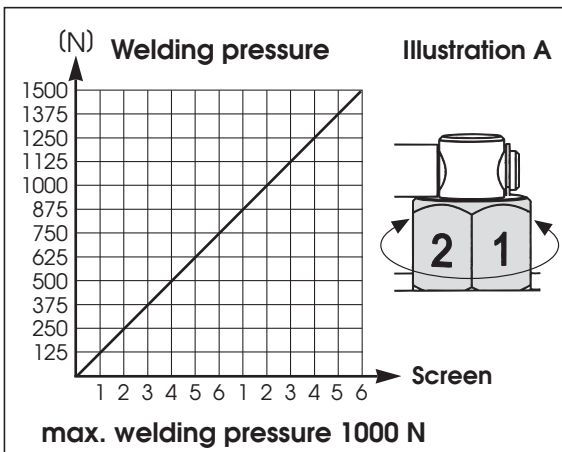

Welding temperature

Set the welding temperature with the **[H]**, **[-]** **[+]** keys. The temperature is dependent on the material and the ambient temperature. The in-put SET value will be shown on the display. Switch on the heating by pressing the **[H]** and **[+]** keys simultaneously. Heating up time approx. 5 mins.

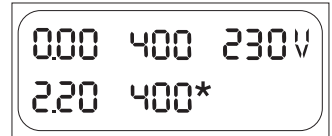
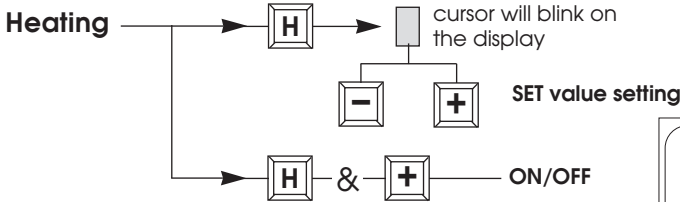

Welding Speed

According on the film or geomembrane liner and the influence of the weather, set the welding speed with the **[-]** **[+]** keys. The in-put SET value will be shown on the display.

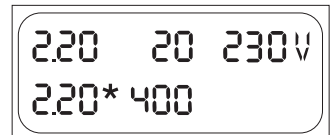
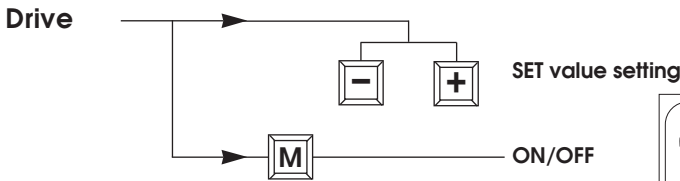

Welding preparation

- *Laying* Width of overlap is about 80mm to 130mm
Geomembrane liners must be clean between the overlap as well as above and below.
- *Mains supply* At least 3kW (generator) **supplied with an RCCB**
- *Cable to mains* A minimum cable cross section in accordance with the table.

200 – 230 V~	to 50 m	3x1,0 mm²
	to 100 m	3x2,5 mm²
120 V~	to 50 m	3x1,5 mm²
	to 100 m	3x2,5 mm²

Operating conditions

- Connect the hot wedge-welding machine to the mains
- Start the machine with Main- or Control Level

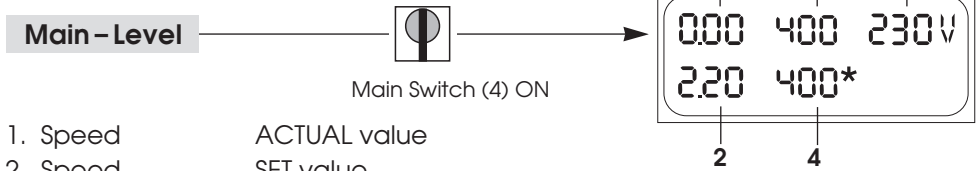

- 1. Speed ACTUAL value
- 2. Speed SET value
- 3. Temperature ACTUAL value
- 4. Temperature SET value
- 5. Voltage display ACTUAL value

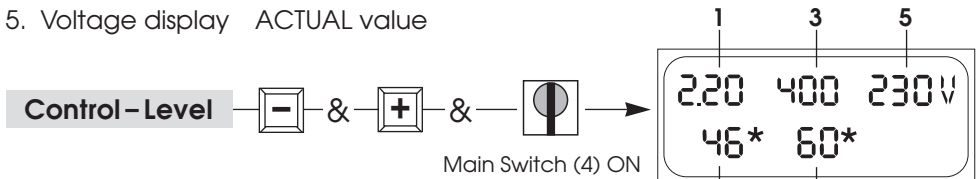

- 1. Speed ACTUAL value
- 2. Speed SET value
- 3. Temperature ACTUAL value
- 4. Temperature SET value
- 5. Voltage display ACTUAL value

*** Heating / Drive active**

< Overload indication

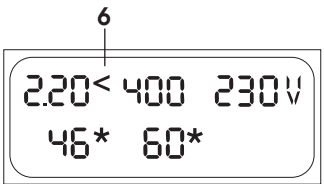

Check the welding process and identify faults by means of the display of power consumption.

Display (4)	Heating reason for fault after heating up time
100 %	• mains under-voltage

Display (2)	Drive reason for fault
100 %	<ul style="list-style-type: none"> • mains under-voltage • overlap of the geomembrane liner too wide • dirt on the drive rollers (20/21) • max. welding pressure (1500 N) has been exceeded • high welding speed with large sudden overload (ie anchoring trench, T-joints...)
100 % or <	
100 % or <<	
100 % or <<<	
100 % or <<<<	

If malfunction does not disappear, contact service center

Welding procedure

- Check:
 - **Drive/ Pressure rollers (20/21)** as well as the **hot wedge (8)** must be clean before engaging into the geomembrane liner or film.
 - Cable length/Cable guide.
- Guide and position the automatic welding machine into the over-lapped geomembrane liner or film.
- Adjust welding parameters, see page 5/6.
- The welding temperature must be achieved.
- Switch on drive motor with **M** key on **keyboard (6)**.
- Pull the **lever (9)**.

Beginning of welding process

- Check the welded seam (wash/seam thickness reduction). As required, adjust the welding speed with **-** **+** keys on **keyboard (6)**.
- The automatic welding machine is guided along the overlap with the **carrying handle/guide handle (12)**, so that the frontal width of the overlap is kept within the 22mm zone (see illustration B).

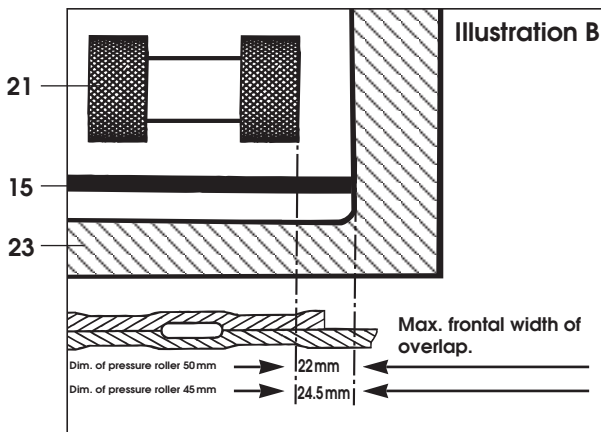

End of welding process

- Release the **tension lever (9)** 1 cm before the end of the welded seam.
- Switch off the drive motor with **M** key on the **keyboard (6)**. Switch off the heating by pressing the **H** and **+** keys on the **keyboard (6)** simultaneously.

Adjusting of the guide rollers for the requested material thickness

- Engage the automatic wedge-welding machine on the geomembrane liner or film to be welded.
- Stretch the **lever (9)**
- Loosen the hexagon cap screw of the **rear guide roller (19)**.
- The distance between the **hot wedge (8)** and the **rear guide roller (19)** should be the thickness of the material and the sharp tongue of the wedge should lie centrally to the **pressure rollers (20/21)**.
- Tighten the hexagon cap screw of the **rear guide roller (19)**.
- Loosen the hexagon cap screw of the **front guide roller (18)**.
- The distance between **hot wedge (8)** and **front guide roller (18)** should be about 1 mm.
- Tighten the hexagon cap screw of the **front guide roller (18)**.

Cross-section diagram of hot wedge system

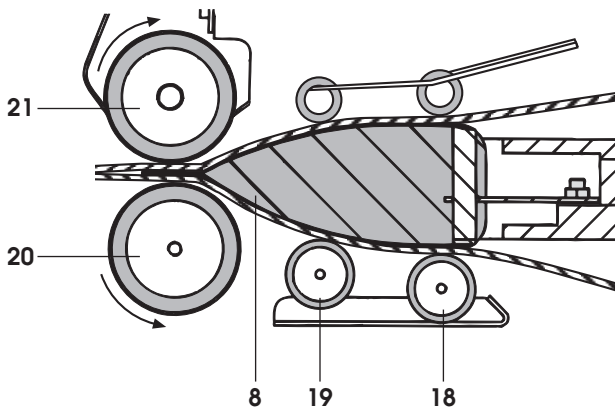

The LEISTER Astro is suitable to manufacture overlap-welded seams in different fields of applications. They differ in the width of the welded seam as well as the width of the test channel. Also welded seams without test channel can be manufactured. In order to implement these different overlap seams, the appropriate drive/pressure rollers have to be installed.

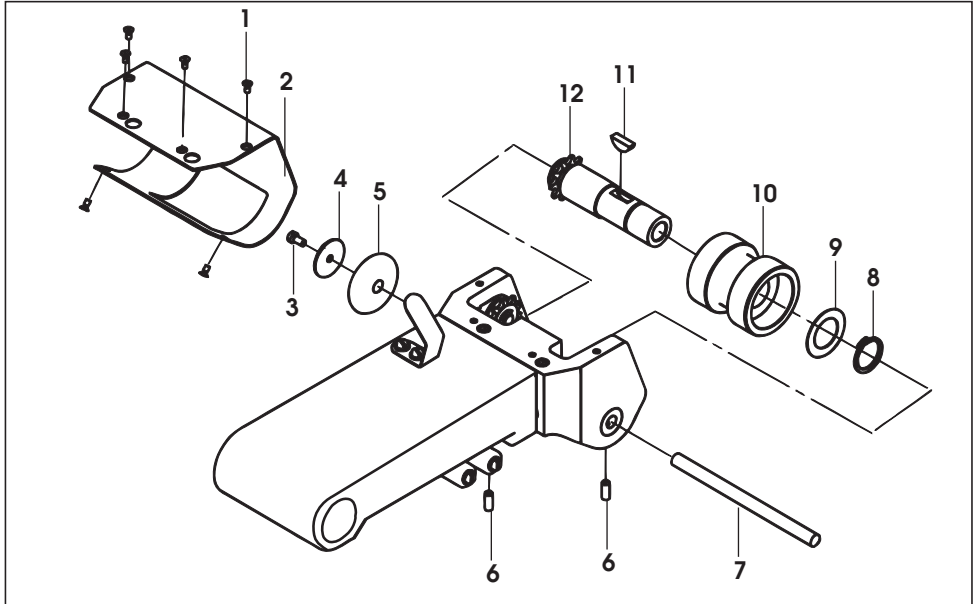

1. Countersunk screw M3×6
2. Protection sheet swivel head
3. Socket head screw M4×8
4. Washer 4.2×25
5. Slide roller
6. Set screw M5×12

7. Shaft 8×118.5
8. Shaft retaining ring
9. Distance disk 20×32×0.5
10. Drive/pressure roller
11. Woodruff key 5×6.5
12. Upper drive shaft complete

Dismantling of the drive/pressure rollers, sequence 1 – 12

Assembly of the drive/pressure rollers, reverse order 12 – 1

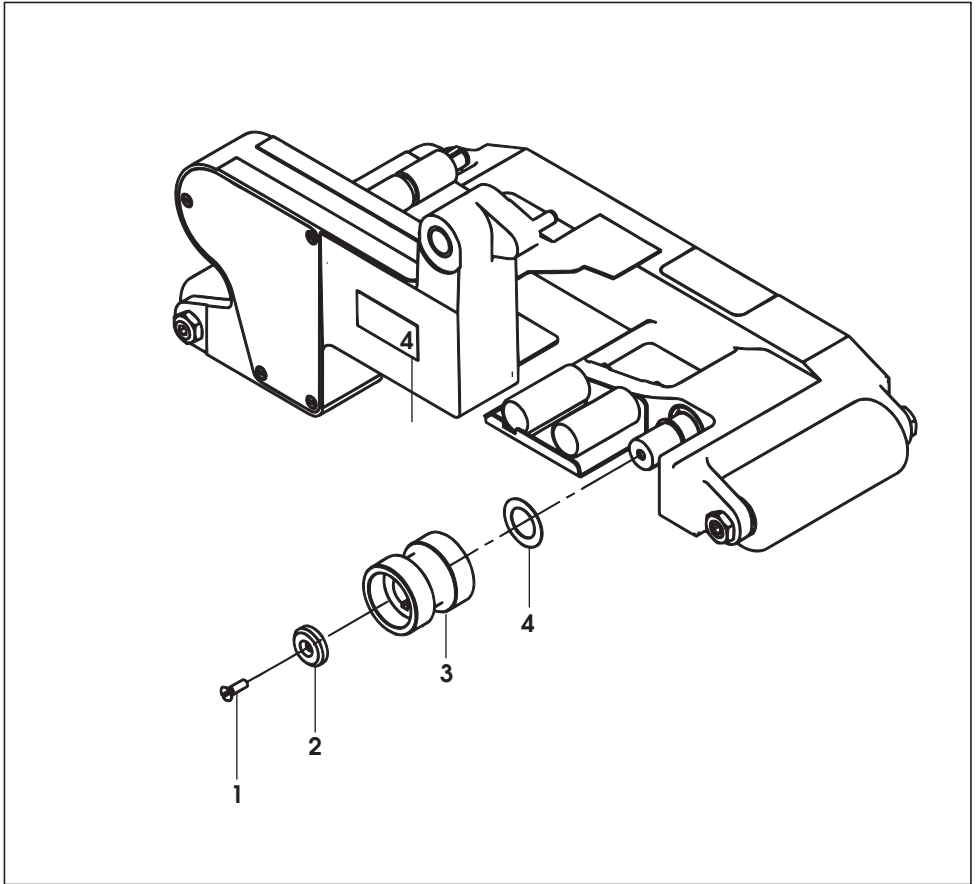

1. Countersunk screw M5×16
2. Clamp disk
3. Drive/Pressure roller
4. Distance disk 20×32×0.5

Dismantling of the drive/pressure rollers, sequence 1 – 4
Assembly of the drive/pressure rollers, reverse 4 – 1

TRAINING

LEISTER Process Technologies and their authorised Service Centres offer free welding courses and training.

ACCESSORIES

- Only LEISTER accessories should be used.

MAINTENANCE

- Check **mains cable (1)** and plug for electrical and mechanical damage.
- Clean **hot wedge (8)** with a copper brush.
- Clean **drive and pressure rollers (20/21)** with a wire brush.
- **Treat chain (22)** with a suitable spray as required (chain guard 23/24).
- Check whether **rollers (13/14/17/18/19)** are running smoothly.

SERVICE AND REPAIR

- The tool should be checked by an authorized Service Center if the following message appears on the **display (5)**: «**maintenance; servicing**».
- Repairs have to be carried out by authorised **LEISTER Service Centres** only. They guarantee a specialized and reliable **repair service within 24 hours** using original LEISTER spare parts.

GUARANTEE AND LIABILITY

- Guarantee and liability are in accordance with the guarantee certificate as well as with the currently valid general business and sales conditions.
- LEISTER Process Technologies rejects any guarantee claims for tools which are not in their original condition. The tools must never be altered or changed.

Technical data and specifications are subject to change without prior notice.

Your authorized Service Centre is: