

LEISTER Comet

Automatic Wedge Welding Machine



Please read operating instructions carefully before use and keep for further reference.

APPLICATION

The LEISTER Comet is an automatic wedge welding machine for overlap welding and manufacturing of films and geomembrane liners in tunnels as well as in earthwork and civil engineering

Note:

For welding materials of **PVC a special wedge** must be used.

Length of Wedge	Type of Material	Material Thickness
70 mm / 2,8 inch	PE-HD, PP, PE-LD, ...	1,5 – 2,0 mm / 60 – 80 mil 2,0 – 3,0 mm / 80 – 120 mil
50 mm / 2 inch	PE-HD, PP, PE-LD, ...	0,5 – 1,5 mm / 20 – 60 mil 1,0 – 2,0 mm / 40 – 80 mil
20 mm / 0,8 inch	PE-HD, PVC-P, PE-LD, ...	0,5 – 1,0 mm / 20 – 40 mil

- **Overlap**
- **Type of seam**

max. 125 mm / 5 inch

Welding seams are produced in accordance with DVS 2225 part I and BAM. Other dimensions are possible on request

DVS: German Welding Association

BAM: Federal Institute for Materials Research and Testing, Berlin.





WARNING



Danger! Unplug the tool before opening it as live components and connections are exposed.



Incorrect use of the hot wedge tool can present a **fire and explosion hazard** especially near combustible materials and explosive gases.



Do not touch the element housing and hot wedge when hot as they can cause **burns**. Allow the tool to cool down. Do not point the hot air flow in the direction of people or animals.



Connect the tool to a **socket outlet with protective earth conductor**. Any interruption of the protective earth conductor within or outside the tool is dangerous! **Use only extensions cables with a protective earth conductor!**



CAUTION



The **voltage rating** stated on the tool should correspond to the mains voltage.



For personal protection, we strongly recommend the tool be connected to an **RCCB (Residual Current Circuit Breaker)** before using it on construction sites.



The tool **must be operated** under supervision. Radiant heat from the hot wedge can ignite flammable materials.



Protect the tool from **damp and wet**.

APPROVAL MARKS



TECHNICAL DATA

Protection class I



Length of wedge

70 mm

50 mm

20 mm

Voltage

V~

120, 230 ★ 120, 230 ★ 120, 230 ★

Power consumption

W

1500 1200 700

Frequency

Hz

50 / 60

Temperature

°C/°F

max. 420 / 790 stepless

Welding pressure

N/lbs pound)

max. 1000 / 225 stepless

Drive

m/min. /feet

0,8 – 3,2 / 2,6 – 10,5 stepless

Size LxBxH

mm

285x230x230

Weight

kg

7,0 (15,5 lbs)

★ mains voltage cannot be switched over

- **Heating system** → The hot air temperature is steplessly adjustable and electronically controlled. According to the material thickness the hot wedge position can be steplessly adjusted as required.

Cross-sectional diagram of hot wedge system

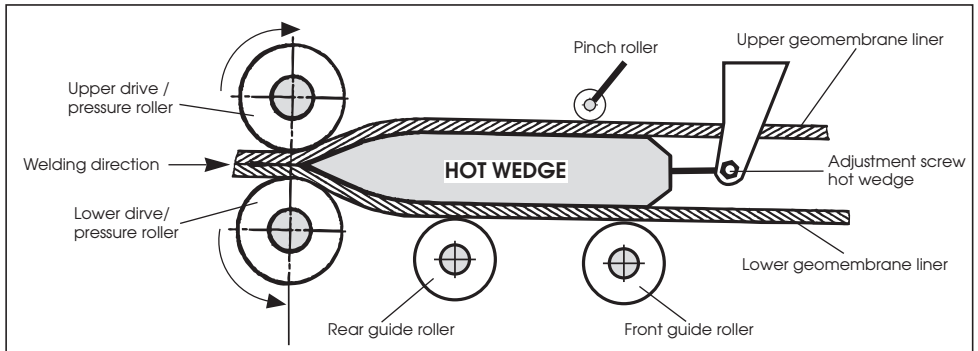

- **Welding Pressure** → steplessly adjustable. The welding pressure is transmitted via a toggle lever to the pressure rollers. The **swivel head guarantees the equalisation of the pressure to both** welded sections (C and D) as well as on a welded seam without test channel. This allows T-joints to be welded easily. During the welding process the pressure adjusts itself linearly to the change in material thickness of the geomembrane liner.

Cross sectional diagram of an overlap weld

Seam thickness reduction = A - B

A : Thickness of the upper and lower membrane

B : Thickness of the welded seam

C : Welded section 1

D : Welded section 2

E : Test channel

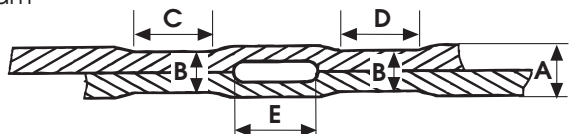

- **Drive** → Double drive system, is steplessly adjustable and electronically controlled. The automatic control system with tachogenerator is designed in such a way, that the adjusted welding speed remains constant independently of the load. The power transmission to the drive/pressure rollers works through a **three stage planetary gear**.

Frontal view

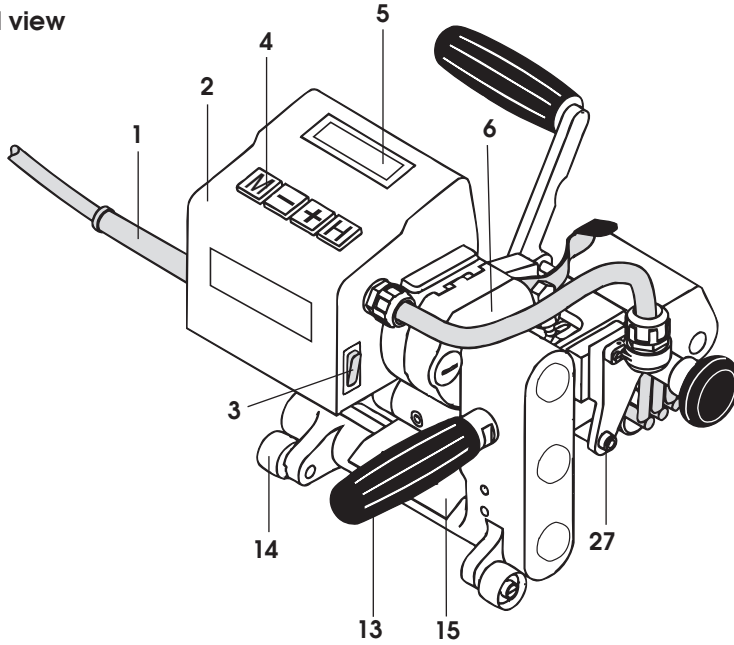

Back view

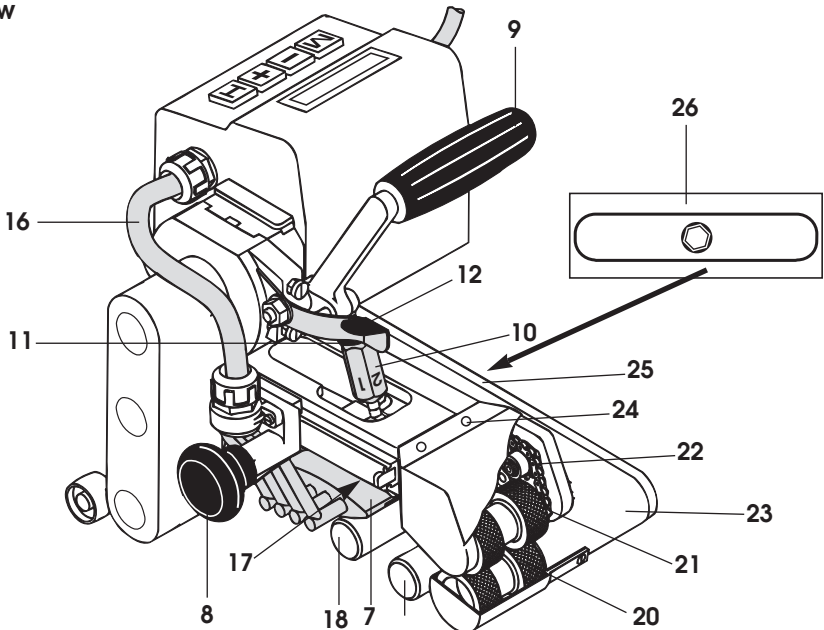

1. Cord to mains
2. Housing for drive motor and electronics
3. Main switch
4. Keyboard
5. Display
6. Drive/power transmission
7. Hot wedge
8. Handle for hot wedge support
9. Lever for welding pressure
10. Adjustment screw for welding pressure
11. Locking screw
12. Lever locking mechanism
13. Guide handle
14. Travelling wheel
15. Deflector
16. Tube to hot wedge
17. Pinch roller
18. Front guide roller
19. Rear guide roller
20. Lower drive/pressure roller
21. Upper drive/pressure roller
22. Chain
23. Lower part of chassis
24. Adjustment screw, swivel head
25. Lower part of chain guard
26. Cap screw for front guide roller
27. Adjustment screw, hot wedge

WELDING PARAMETERS

LEISTER Comet

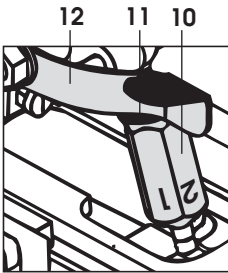

- Welding Pressure

Engage and position the automatic welding machine onto the material to be welded. Pull the **lever for welding pressure (9)** without engaging the hot wedge. By rotating the **adjustment screw for welding pressure (10)** the **drive/pressure rollers (20/21)** should lightly touch the material to be welded. Unlock the lever for the **locking mechanism (12)** and release the tension of the **lever (9)** at the same time.

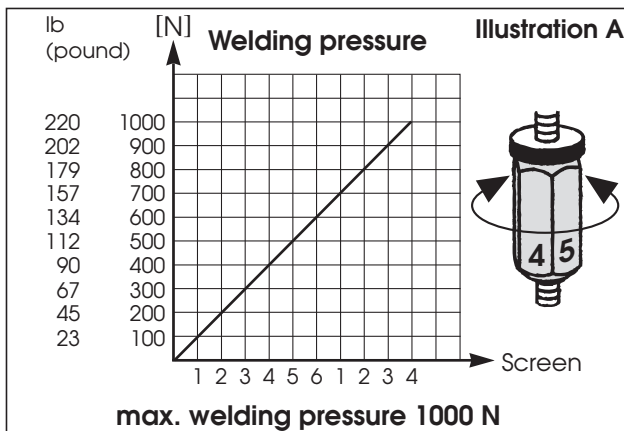

Following **illustration A**, rotate the **adjustment screw (10)**. Tighten the **locking screw (11)** by hand.

Warning:

If the maximum welding pressure of 1000 N is exceeded mechanical damage may occur.

Welding temperature

Set the welding temperature with the **[H]**, **[-]** **[+]** keys. The temperature is dependent on the material and the ambient temperature. The in-put SET value will be shown on the display. Switch on the heating by pressing the **[H]** and **[+]** keys simultaneously. Heating up time approx. 5 mins.

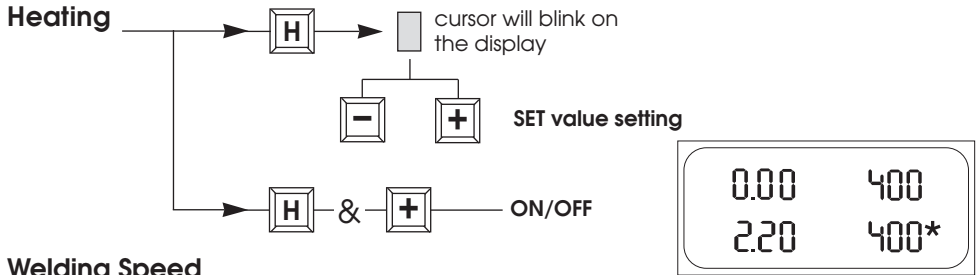

Welding Speed

According on the film or geomembrane liner and the influence of the weather, set the welding speed with the **[-]** **[+]** keys. The in-put SET value will be shown to the display.

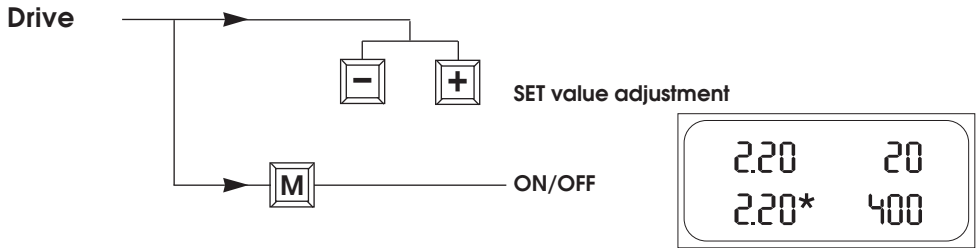

Welding Preparation

- *Laying* Width of overlap 80 mm to 125 mm
Geomembrane liners must be clean between the overlap as well as above and below.
- *Mains supply* at least 4kW (generator)
supplied with an RCCB
- *Cable to mains* a minimum cable cross section in accordance with the table.

230 V~	to 50 m	3x1,5 mm ² / 3x14 AWG
	to 100 m	3x2,5 mm ² / 3x12 AWG
120 V~	to 50 m	3x1,5 mm ² / 3x14 AWG
	to 100 m	3x2,5 mm ² / 3x12 AWG

Operating conditions

- Attach **guide handle (13)**.
- Pull out **handle (8)** and pull back the hot wedge support by the **handle (8)** until it locks again.
- Connect tool to the mains.
- Start the tool with Main or Control Level.

Version:

Standard

Memory card

Main - Level



1	3
0.00	400
2.20	400*
2	4

1	3	5
180<	20	850
190*	400	365
2	4	6

Control - Level



1	3
2.20<	400
46*	60*
2	4

1	3	5
180	380	850
47*	60*	?365
2	4	7 6

Check the welding process and identify faults by means of the display of power consumption.

Display no.	Level	
	Main	Control
1. Welding speed	ACTUAL value	
2. Welding speed	SET value	Power consumption
3. Temperature	ACTUAL value	
4. Temperature	SET value	Power consumption
5. Welding pressure	ACTUAL value	
6. Memory card	Residual capacity	

< Overload Indication
*** Heating / Drive active**

Memory card	Autostart	No.7	Residual capacity (Pos.7)	Led green	Led red
Not inserted	No / Yes	(none)	0	Off	Off
Inserted	No	?	365*	On	Off
	Yes				
Protocol on	No /Yes	→	364*	On	flashing

Display (4)	Heating reason for fault after heating up time
100 % 100 %	<ul style="list-style-type: none"> mains under-voltage heating cartridges faulty

Display (2)	Drive reason for fault
100 % 100 % or < 100 % or < 100 % or < 100 % or <	<ul style="list-style-type: none"> mains under-voltage overlap of the geomembrane liner too wide dirt on the drive rollers (20/21) max. welding pressure (1000 N) has been exceeded. high welding speed with large sudden overload (ie anchoring trench, T-joints....)

If malfunction is still present, contact service centre.

Welding procedure

- Check:
 - **Drive Pressure rollers (20/21)** as well as the **hot wedge (7)** must be clean before engaging into the geomembrane liner or film.
 - Cable length/cable guide
- Guide and position the automatic welding machine into the over-lapped geomembrane liner or film.
- Adjust welding parameters, see page 5/6.
- The welding temperature must be achieved.
- Switch on drive motor with **M** key on **keyboard (4)**.
- Engage the **hot wedge (7)**.
- Pull the **lever (9)**.

Beginning of welding process

- Check the welded seam (wash/seam thickness reduction). As required, adjust the welding speed with **-** **+** keys on **keyboard (4)**.
- The automatic welding machine is guided along the overlap with the **guide handle (13)**, so that the frontal width of the overlap is kept within the 20 mm / 0,8 inch zone (see illustration B).

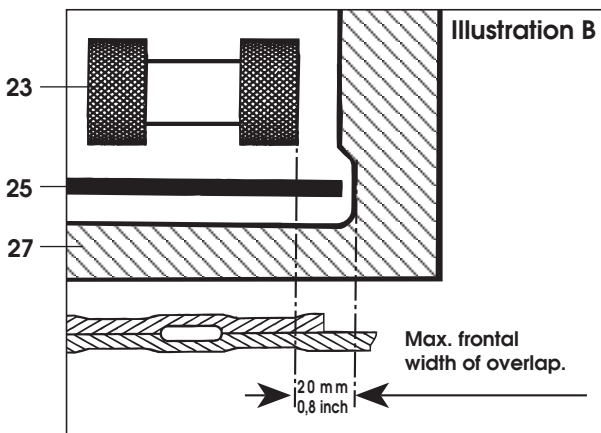

End of welding process

- 1 cm before the end of the welded seam release the **tension lever (9)** and pull the **hot wedge (7)** out of the overlap and lift up.
- Switch off the drive motor with **M** key on the **keyboard (4)**. Switch off the heating by pressing the **H** and **+** keys on the **keyboard (4)** simultaneously.

The hot wedge can be adjusted according to the material thickness as required.

- Engage the automatic wedge welding machine onto the geomembrane liner or film to be welded.
- Engage the **hot wedge (7)**.
- Set the **tension lever (9)** to the specified welding pressure.
- Remove the **lower part of the gear housing (25)**.
- Loosen the **cap screw (26)**.
- Loosen the hexagon cap screw of the **rear guide roller (19)**.
- Adjust the **rear guide roller (19)** to the correct height. The distance between the **hot wedge (7)** and the **rear guide roller (19)** should be the thickness of the material.
- Tighten the hexagon cap screw of the **rear guide roller (19)**.
- Loosen the **adjustment screw for the hot wedge (27)**. The **hot wedge (7)** will automatically align itself with the geomembrane liner.
- Tighten the **adjustment screw for the hot wedge (27)**.
- Adjust the **front guide roller (18)** to the correct height. The distance between the inserted material and the **front guide roller (18)** should be ca.<1 mm.
- Tighten the **hexagon cap screw (26)**. While doing so the **front guide roller (18)** must be held with a hexagon cap screw.
- Assemble **chain guard lower part (25)**.
- **Test weld.**

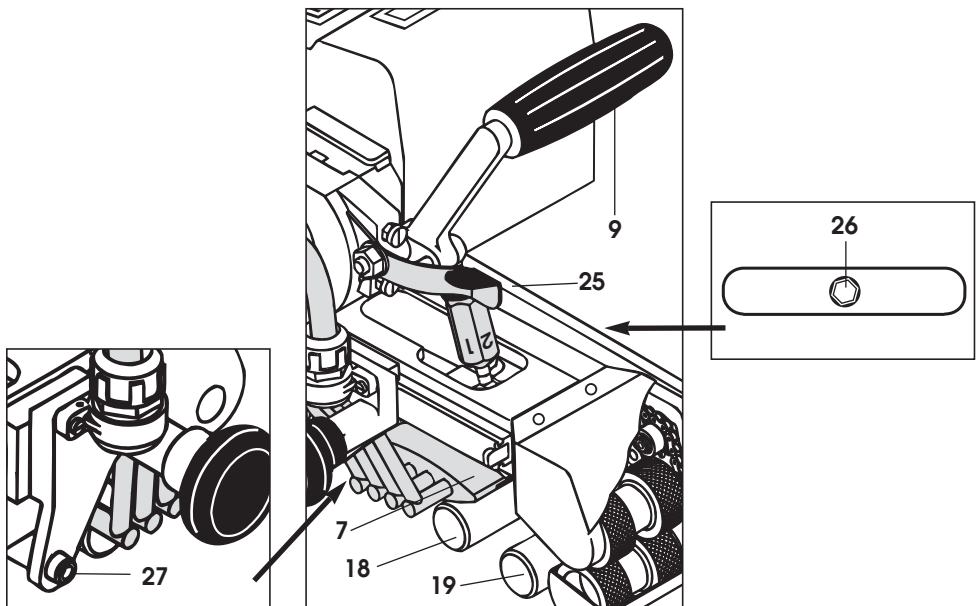

For various applications, for example tunnel construction or civil engineering at or below ground level, various overlap-welded seams can be manufactured with the LEISTER Comet. These differ in the width of the welded seam and the width of the test channel. Also welded seams without a test channel can be manufactured. In order to implement these different overlapped seams, the appropriate drive/pressure rollers must be fixed. These drive/pressure rollers can be produced in aluminium or stainless steel according to the customer's requirements.

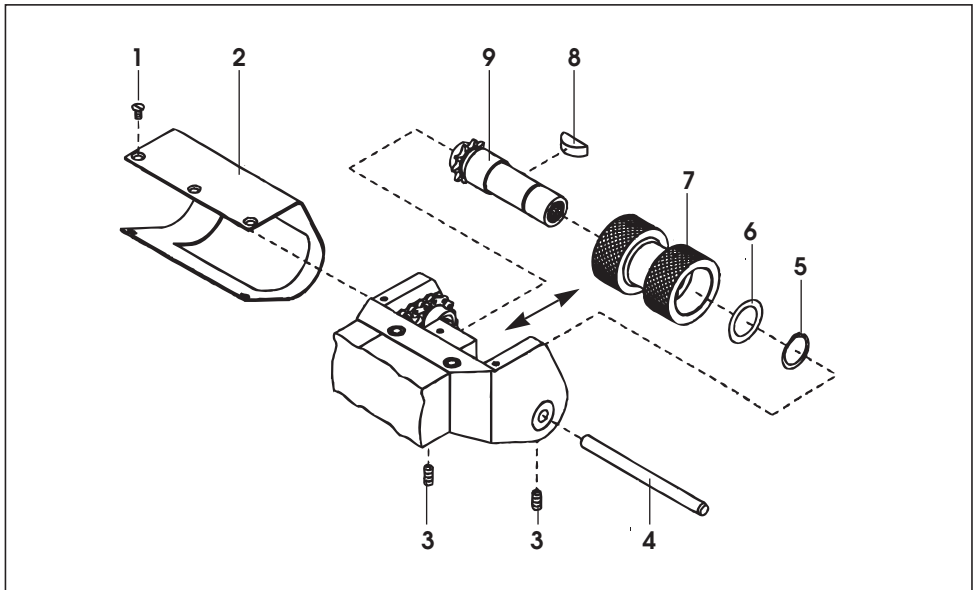

- | | |
|--|---------------------------------|
| 1. Countersunk screw M3x6 | 6. Spacer ring |
| 2. Guard plate for swivelling head | 7. Drive/pressure roller |
| 3. Set screw M4x8 | 8. Woodruff key |
| 4. Straight pin 6x80 | 9. Drive shaft, upper complete |
| 5. Locking ring (shaft \varnothing 15) | |

Dismantling of the drive pressure rollers, sequence 1 – 9
Assembly of the drive/pressure rollers, reverse order 9 – 1

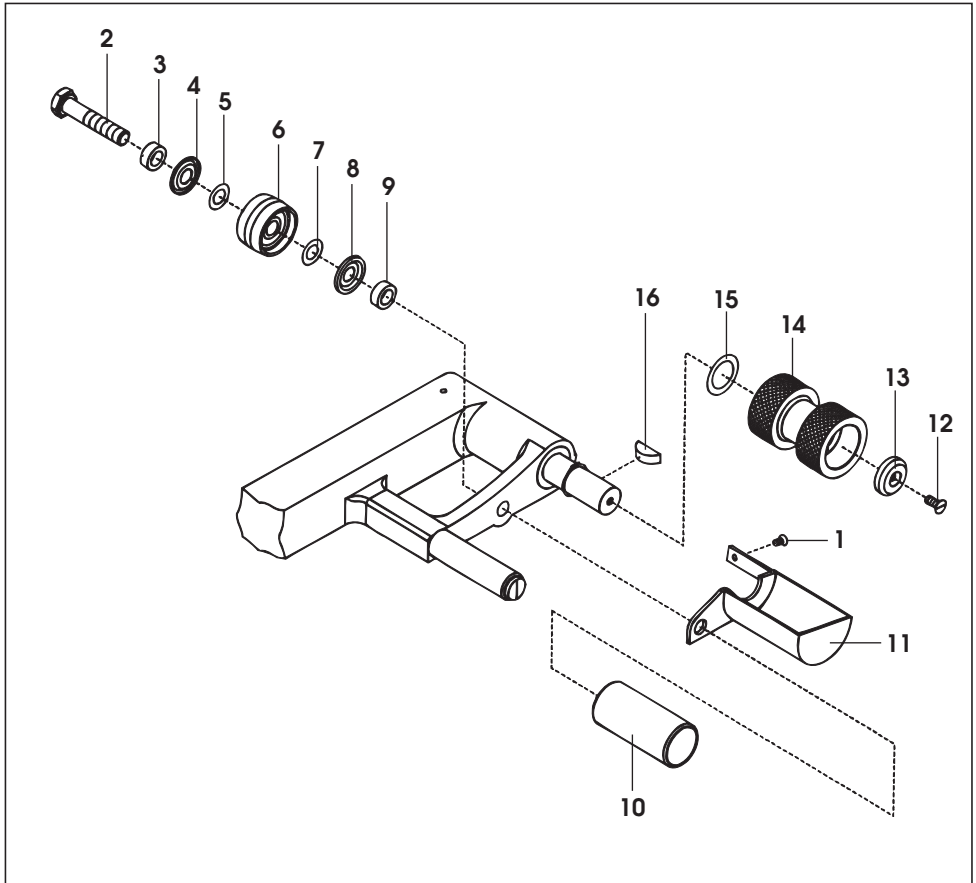

- | | |
|--------------------------------------|---------------------------------------|
| 1. Countersunk screw M3x6 | 9. Spacer bush |
| 2. Cylinder screw M8x40 | 10. Guide roller |
| 3. Spacer bush | 11. Guard plate drive/pressure roller |
| 4. Nilos-ring \varnothing 8/20x1,8 | 12. Countersunk screw M4x12 |
| 5. Shim \varnothing 8/14x0,1 | 13. Locking washer |
| 6. Rear travelling wheel complete | 14. Drive/pressure roller |
| 7. Shim \varnothing 8/14x0,1 | 15. Spacer \varnothing 15/22x0,3 |
| 8. Nilos-ring \varnothing 8/20x1,8 | 16. Woodruff key 5x6,5 |

Dismantling of the drive/pressure rollers, sequence 1 – 16
Assembly of the drive/pressure rollers, reverse 16 – 1

TRAINING

- LEISTER Process Technologies and their authorised Service Centres offer free welding courses and training.

ACCESSORIES

- Only LEISTER accessories should be used.

MAINTENANCE

- Clean the **hot wedge (7)** with a wire brush.
- Clean the drive and **pressure roller (20/21)** with a wire brush.
- Treat the **chain (22)** with a suitable spray as required.
- Check **mains cable (1)** and plug for electrical and mechanical damage.

SERVICE AND REPAIR

- The tool should be checked after a maximum of approx. 1000 hours running time by an authorised Service Centre
- Repairs have to be carried out by authorised **LEISTER Service Centres** only. They guarantee a specialized and reliable **repair service within 24 hours** using original LEISTER spare parts.

GUARANTEE AND LIABILITY

- Guarantee and liability are in accordance with the guarantee certificate as well as with the currently valid general business and sales conditions.
- LEISTER Process Technologies rejects any guarantee claims for tools which are not in their original condition. The tools must never be altered or changed.

Technical data and specifications are subject to change without prior notice.

Your authorized Service Centre: STAR Process Heat Systems, 877-782-7747