

LEISTER Varimat V Hot Air Automatic Welding Machine



Please read operating instructions carefully before use and keep for further reference.

APPLICATION

LEISTER Varimat Automatic Overlap Welding Machine

- For overlap welding of roofing membranes made of PVC, PE, ECB, EPDM, CSPE, and Modified Bitumen for areas close to edges and uneven surfaces.
- Overlap welding of foils and coated materials. Width of welding seam 20, 40 mm.

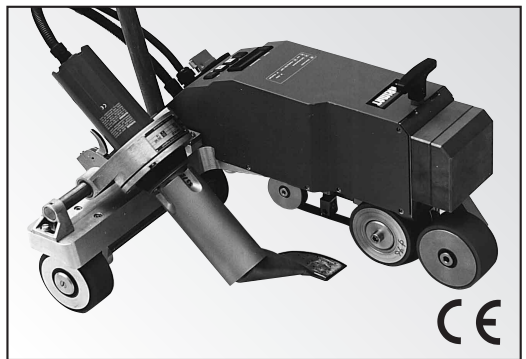

LEISTER Varimat Automatic Bitumen Welding Machine

For overlap welding of Modified Bitumen sheet. Width of welding seam 80, 100 or 120 mm.

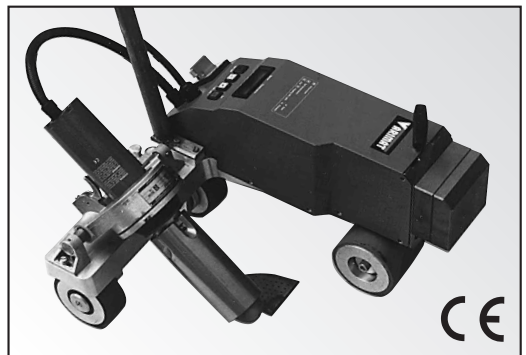



WARNING



Danger! Unplug the tool before opening it as live components and connections are exposed.



Incorrect use of the hot air tool can present a **fire and explosion hazard** especially near combustable materials and explosive gases.



Do not touch the element housing and nozzle when hot as they can cause **burns**. Allow the tool to cool down. Do not point the hot air flow at people or animals.



Connect tool to a **receptacle with protective earth terminal**. Any interruption of the protective conductor inside or outside the tool is dangerous!

Line/mains extension cables must always have a protective ground conductor!



CAUTION



The **voltage rating** stated on the tool should correspond to the mains voltage.



For personal protection, we strongly recommend the tool be connected to an **RCCB (Residual Current Circuit Breaker)** before using it on construction sites.



The tool **must** be operated under supervision. The heat can ignite flammable materials which are not in view.



Protect the tool from **damp** and **wet**.

APPROVAL MARKS



Technical Data	Protection Class I	
Voltage	V~	230, 400 ★
Power consumption	W	230, 400 ★
Frequency	Hz	4600, 5700
Temperature	°C	4600, 6300
Drive	m/min.	50 / 60
Welding pressure	N	20 – 620 stepless
Air flow	%	0,5 – 5 stepless
Emission level	L _{pA} (dB)	ca. 190 (2 weights)
Size	mm	ca. 220 (2 weights)
Weight	kg	50 – 100
		67
		67
		640 x 430 x 330
		640 x 430 x 330
		33 with 5 m cable
		35 with 5 m cable

★ Mains voltage cannot be switched over

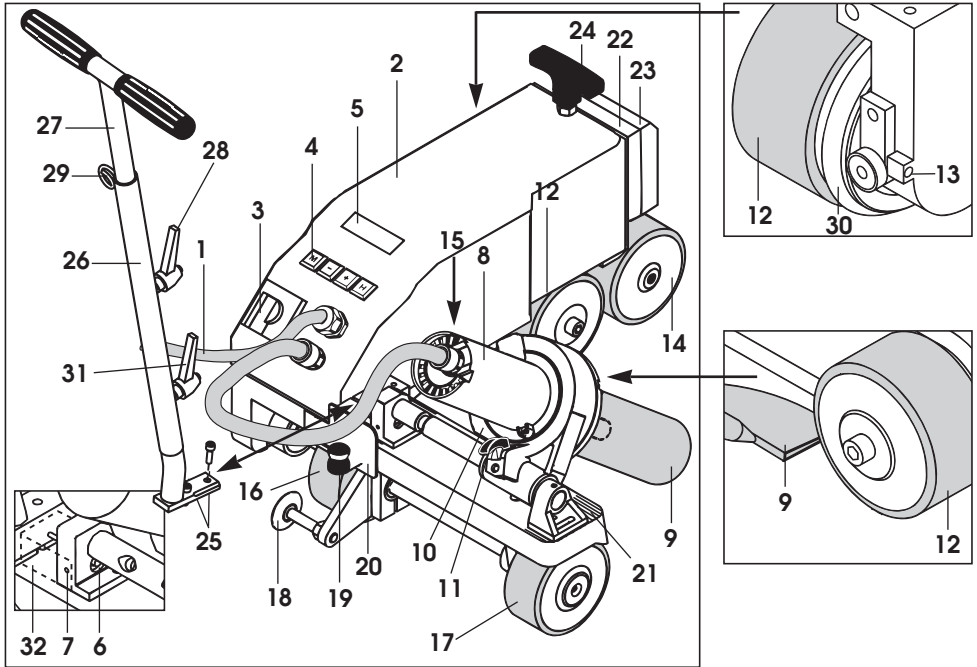

1. Cable to mains
2. Housing
3. Main switch
4. Key board
5. Display
6. Sensor
7. Locking screw
8. Hot air blower
9. Welding nozzle
10. Tool holder
11. Locking lever
12. Pendulum action roller
13. Adjustment screw for tracking
14. Track-alignment roller
15. Guide roller
16. Adjustable transport roller
17. Transport roller
18. Guide roller
19. Shift spring for transport roller
20. Gate
21. Scale for tool adjustment
22. Additional weight

23. End weight
24. Carrying handle
25. Socket head cap screw
26. Lower guide bar
27. Upper guide bar
28. Clamping lever guide bar height adjustable
29. Cable holder
30. Round belt
31. Clamping lever guide bar
32. Sensor covering

12 Pendulum action roller

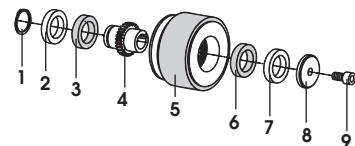

- | | |
|-------------------|--------------------|
| 1. Retaining ring | 6. Rubber buffer |
| 2. Tension ring | 7. Tension ring |
| 3. Rubber buffer | 8. Tightening disk |
| 4. Tappet casing | 9. Cylinder screw |
| 5. Rubber tyre | |

Main-Level

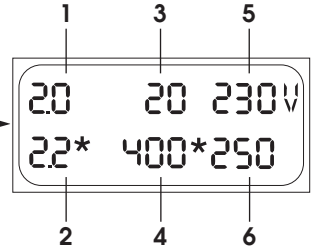

Display of:

1. Welding speed ACTUAL value
2. Welding speed SET value
3. Temperature ACTUAL value
4. Temperature SET value
5. Voltage - ACTUAL value
6. Welded length - ACTUAL value

Control-Level

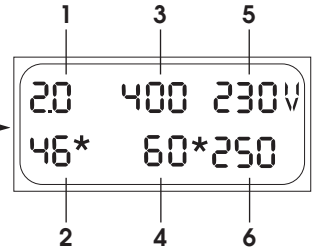

Display of:

- | | |
|------------------|------------------------------------|
| 1. Welding speed | ACTUAL value |
| 2. Welding speed | Power consumption in % after start |
| 3. Temperature | ACTUAL value |
| 4. Temperature | Power consumption in % after start |
| 5. Voltage | ACTUAL value |
| 6. Welded length | ACTUAL value |

*** Heating / Drive active**

Display 2	Heating reason for fault	Action
100 % <small>SET value</small> 100 % <small>not achieved</small>	<ul style="list-style-type: none"> • mains under-voltage • heating element faulty 	reduction of airflow repair

Display 4	Drive reason for fault	Action
100 %	<ul style="list-style-type: none"> • mains under-voltage • high welding speed with large sudden overload 	reduction of welding speed check welding procedure/machine

Automatic starter reason for fault

Drive motor **does not start automatically** after the nozzle has been positioned

- **Sensor (6)** set incorrectly

Action adjust Sensor

- Switch off **main switch (3)**
- **Remove sensor covering (32)**
- Lower the **hot air blower (8)** and guide it to the left until it locks
- **Locking lever (11)** must click in
- Loosen **locking screw for sensor (7)**
- Push **sensor (6)** to **tool holder (10)**
 IMPORTANT! Distance between tool holder and sensor > 0,2 – 0,5mm max.
- Tighten locking **screw for sensor (7)**
- Fix **sensor covering (32)**
- Move the **hot air blower (8)** out until it locks and swivel up
- Make a functional test

If malfunction is still present, contact your Service Center.

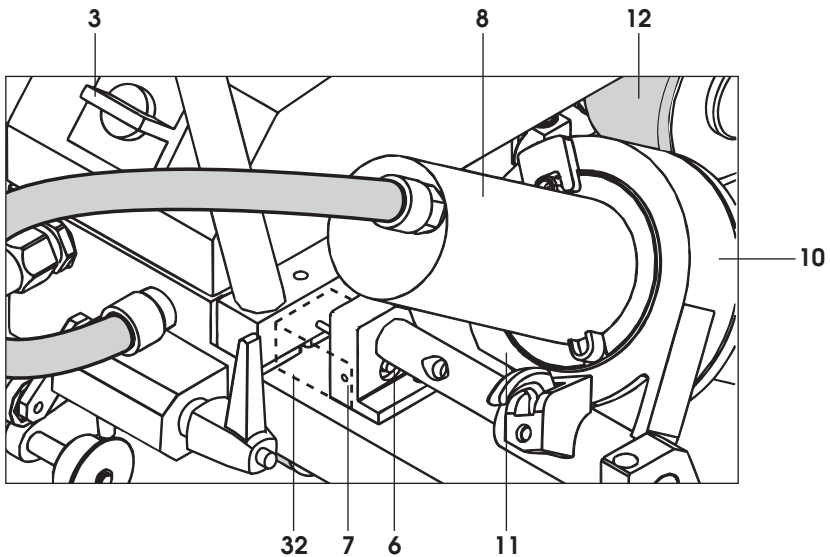

Error 100/ 101/ 102	Measures
check the blower	<ul style="list-style-type: none"> • Check blower (air must be flowing out of nozzle) • If malfunction is still present, contact your Service Center

Welding Temperature

Set the welding temperature with the **[H]**, **[-]** **[+]** keys. The temperature is dependent on the material and the ambient temperature. The in-put SET value will be shown on the display. Switch on the heating by pressing the **[+]** and **[H]** keys simultaneously. Heating-up time approx. 5 mins. (SET value not achieved, see airflow).

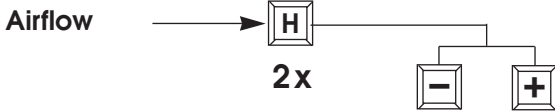
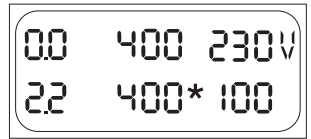
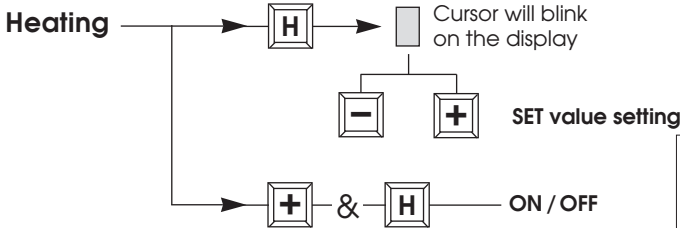

Important note:

During the heating-up process, the airflow is adjusted automatically to 100%. Only after reaching the SET temperature, the pre-set airflow in %, is taken over (element protection). If the SET temperature has not been achieved, adjust the airflow to 80% before switching on the heating element.

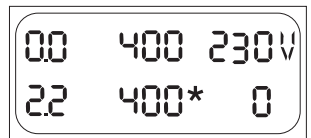

Welding speed

Depending on the film or geomembrane liner and the influence of the weather, set the welding speed with the **[-]** **[+]** keys. The in-put SET value will be shown on the display.

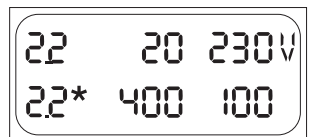
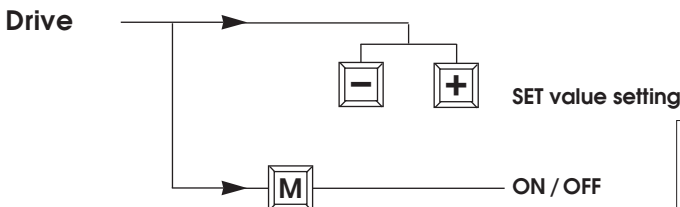

Welding pressure

- The welding pressure is transmitted to the **pendulum action roller (12)**.
- As necessary, the **additional weights (22)** and the **end weight (23)** can be put on (see illustration H).

Illustration H

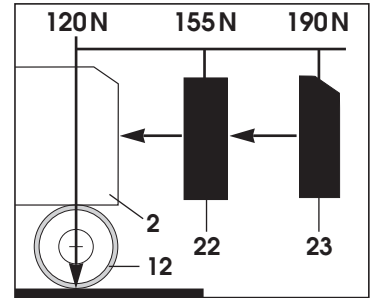
**Operating condition**

- Attach strain relief of **guide bar (26/27)**
- Hang the **mains cable (1)** into the **cable holder (29)**.
- Adjust the **guide bar (27)** with the **clamping lever (28)** to the desired height
- Check the basic setting of the **welding nozzle (9)**.
(ex works illustration A and C)
- **Transport setting:**
 - Swivel the **guide roller (18)** upwards
 - Release the **transport roller (16)** by raising the **guide bar (27)**.
 - Push the **transport roller (16)** by applying a little pressure to the **shift spring (19)** to the left until it stops (illustration B).
 - Position the **hot air blower (8)** by pulling the **locking lever (11)** and swivel it up until it locks.
- Connect the tool to the mains
The voltage rating stated on the tool should correspond to the mains voltage.

Illustration A



1-2 mm

Illustration B

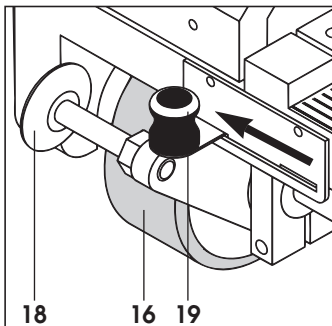
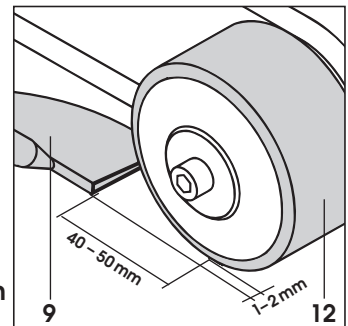

Illustration C



Tool positioning

- Tip up the Automatic Welding Machine by applying pressure to the **guide bar (27)** and position it ready for welding.
- Release the **transport roller (16)** by lifting it with the **guide bar (27)**.
- Push the **transport roller (16)** to the left until it stops by applying light pressure to the **shift spring (19)**.
- Swivel **the guide roller (18)** down.
- The **guide roller (18)** should be set parallel to the edge of the **pendulum action roller (12)** (see illustration E)
- Do a test run
- To correct the tracking, adjust the **adjustment screw for tracking (13)** (see illustration F and G, and the function notes on the automatic welding machine).

Illustration E

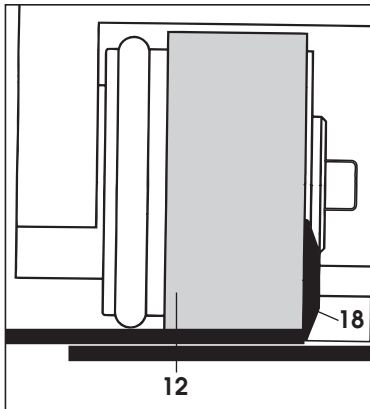

Illustration F

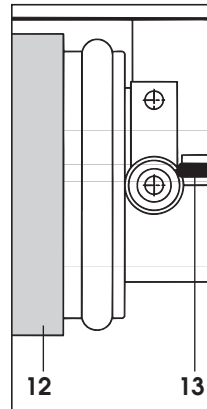
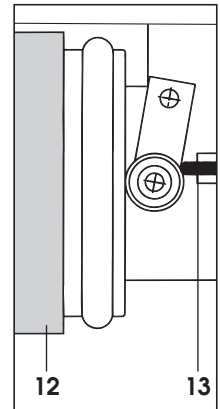

Illustration G



Welding procedure

- Adjust welding parameter, see page 6.
- The welding temperature must be achieved (heating up time approx. 5 min).
- **Do a test run.**
- Pull the **locking lever (11)**, lower the **hot air blower (8)** and position it between the overlapped sheets until it stops.
If it does not start, see sensor adjustment, page 5.
The machine can be started manually with key **M**
- The automatic welding machine is guided along the overlap with the **guide bar (27)**. Do not apply pressure to **the guide bar (27)** this could lead to welding faults. Keep watching the **guide roller (18)** position.
- After welding, pull the **locking lever (11)**, take the **hot air blower (8)** out until it stops and swivel up until it locks.
- After completion of the welding work switch off the heater by pressing keys **+** and **H** on **keyboard (4)** simultaneously, so that the **welding nozzle (8)** cools down.
- Switch off **main switch (3)**.

Welding pressure

- The welding pressure is transmitted to the **pendulum action roller (12)**.
- As necessary, the **additional weights (22)** and the **end weight (23)** can be put on (see illustration H).

Illustration H

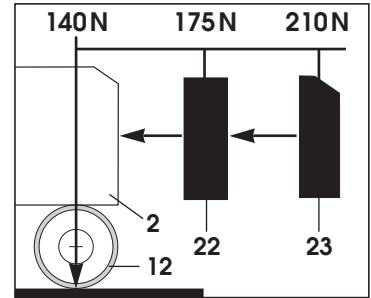

OPERATION

Overlap 80/100/120 mm

LEISTER Varimat V

Operating condition

- Attach the **guide bar (26/27)**.
- Hang strain relief of **mains cable (1)** in the **cable holder (29)**.
- Adjust the **guide bar (27)** with the **clamping lever (28)** to the desired height
- Check the basic setting of the **welding nozzle (9)**. (ex works detail A and C).
- Transport setting:
 - Swivel the **guide roller (18)** upwards.
 - Release the **transport roller (16)** by lifting up with the **guide bar (27)**.
 - Push the **transport roller (16)** by applying a little pressure to the **shift spring (19)** to the left until it stops (illustration B).
 - Position the **hot air blower (8)** by pulling the **locking lever (11)** and swivel it up until it locks.
- The basic adjustment of the **welding nozzle (9)** is done at the factory (Illustration A and C)
- Connect the tool to the mains.
The voltage rating stated on the tool should correspond to the mains voltage.

Illustration A

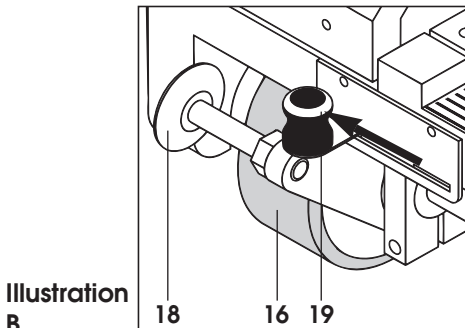
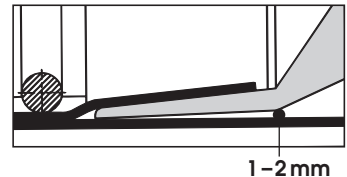

Illustration B

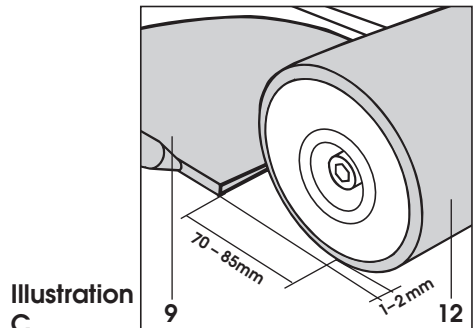

Illustration C

Tool positioning

- Tip up the Automatic Welding Machine by applying pressure to the **guide bar (27)** and position it ready for welding.
- Release the **transport roller (16)** by lifting it with the **guide bar (27)**.
- Push the **transport roller (16)** to the left until it stops by applying light pressure to the **shift spring (19)**.
- Swivel the **guide roller (18)** down.
- The **guide roller (18)** should be set parallel to the edge of the **pendulum action roller (12)** (see illustration E).
- Do a test run
- To correct the tracking, adjust the **adjustment screw for tracking (13)** (see illustration F and G, and the function notes on the automatic welding machine).

Illustration E

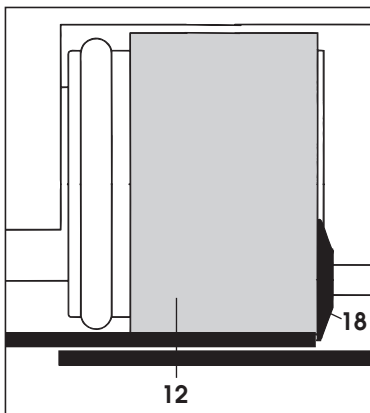

Illustration F

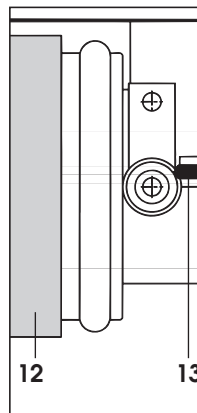
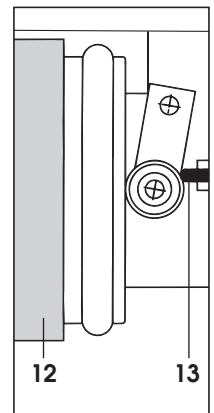

Illustration G



Welding procedure

- Adjust welding parameters, see page 6.
- The welding temperature must be achieved (heating up time approx. 5 min.). If the temperature is not achieved, reduce the airflow.
- **Do a test run.**
- Pull the **locking lever (11)**, lower the **hot air blower (8)** and position it between the overlapped sheets until it stops. The drive motor will start automatically. If it does not start, see sensor adjustment, page 5.
The machine can be started manually by pressing key **M**.
- The automatic welding machine is guided along the overlap with the **guide bar (27)**. Do not apply pressure to the **guide bar (27)** this could lead to welding faults. Keep watching the **guide roller (18)** position.
- After welding, pull the **locking lever (11)**, take the **hot air blower (8)** out until it stops and swivel up until it locks.
- When the welding is completed switch off heater with the **+** and **H** keys on the **keyboard (4)**, so that the **welding nozzle (8)** cools down.
- Switch off **main switch (3)**.

ACCESSORIES

- Only LEISTER accessories should be used.

TRAINING

LEISTER and its authorized Service Centres offer welding courses world-wide free of charge. If necessary, customers will also receive training on site.

MAINTENANCE

- Clean the **welding nozzle (9)** with a wire brush.
- Clean air inlet to **blower (8)**.
- Check **mains cable (1)** and plug for electrical and mechanical damage.

SERVICE AND REPAIR

- If display shows the message «**maintenance; servicing**» the machine must be examined by an authorised LEISTER service centre.
- Repairs have to be carried out by authorised **LEISTER Service Centres** only. They guarantee a specialized and reliable **repair service within 24 hours** using original LEISTER spare parts.

GUARANTEE AND LIABILITY

- Guarantee and liability are in accordance with the guarantee certificate as well as with the currently valid general business and sales conditions.
- LEISTER Process Technologies rejects any guarantee claims for tools which are not in their original condition. The tools must never be altered or changed.

Technical data and specifications are subject to change without prior notice.

Authorized Service Center: STAR Process Heat Systems, NJ - 877-782-7747



Service Record LEISTER Varimat V

This document should be kept up to date during repair or servicing by the authorized LEISTER Service Centre. This document should be in the possession of the owner of the equipment.

Technical data

Type of Automatic Hot Air Welding Machine

Order No.

Serial No

Rated voltage **V**

Rated capacity **W**

Sale **date**

Service

- 1. Date Service Centre Signature
- 2. Date Service Centre Signature
- 3. Date Service Centre Signature
- 4. Date Service Centre Signature
- 5. Date Service Centre Signature
- 6. Date Service Centre Signature

Repair

- 1. Date Service Centre Signature
- 2. Date Service Centre Signature
- 3. Date Service Centre Signature