

# LEISTER Hot-Jet S □ Hot Air Welding Tool



Please read operating instructions carefully before use and keep for further reference.

## APPLICATION

- **Soldering and de-soldering** of SMD thru-hole components.
- **Welding** of thermoplastic materials and also single-ply flexible plastics and modified bitumen in the form of boards, tubes, profiles, lining membranes, coated materials, films, foams, tiles, and sheets. The following procedures are possible: overlap welding, welding with rod, with tape and fusion welding by heat.
- **Shrinking** of heat-shrink sleeves, films, tapes, solder sleeves and moulded parts.
- **Activating/dissolving** of solvent free adhesives and fusion adhesives.
- **Drying** of water-damp surfaces.

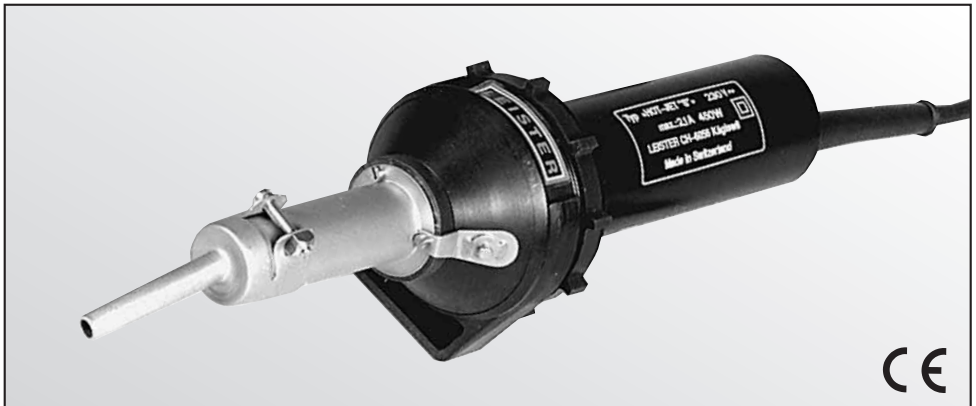



## WARNING



**Danger to life** when opening the tool, as live components and connections are exposed. Unplug the tool before opening it.



Incorrect use of hot air blowers can cause **fire and explosion hazard**, especially near combustible materials and explosive gases.



Do not touch the element housing and nozzle when they are hot as they can cause **burns**. Let the tool cool down. Do not point hot air flow in the direction of people or animals.



## CAUTION



The **voltage rating** stated on the tool must correspond to the line/mains voltage.



For personal protection on building sites we **strongly recommend** the tool be connected to a **GFCI** (Ground Fault Circuit Interrupter) or a **RCCB** (Residual Current Circuit Breaker).



The tool must be operated **with supervision**. Warmth can reach combustible materials, which are out of sight.



Protect tool from **damp** and **wet**.

## APPROVAL MARKS



This tool is **CCA** certificated (CENELEC Certification Agreement).

## TECHNICAL DATA

Electrical safety:  double insulated

Voltage	V~	100, 120, 230, for 50/60 Hz	Mains voltage cannot be switched over
Power consumption	W	460, 460, 460	
Temperature	°C	20 – 600, steplessly controlled	
Air flow	l/min.	20 – 80, steplessly adjustable	
Air pressure	mbar	max. 16	
Noise level	dB (A)	59	
Weight	g	375 without cable, 580 with 3m cable	
Size	mm	235 x 70, handle Ø 40	

**Description of tool**

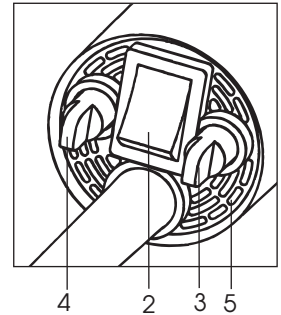
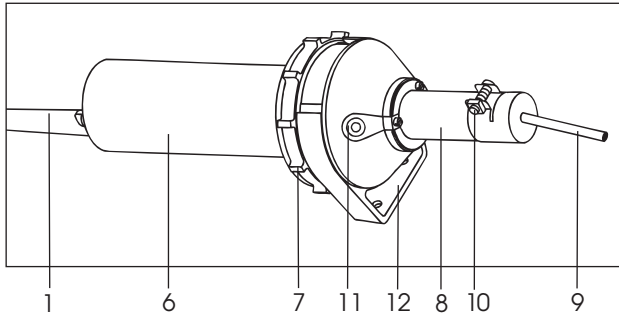

- |   |   |
|---|---|
| 1. Cable to mains                           | 7. Rubber stand                                 |
| 2. On/off switch                            | 8. Element housing                              |
| 3. Potentiometer for temperature adjustment | 9. Nozzle                                       |
| 4. Potentiometer for air flow adjustment    | 10. Clamp with screw to push-fit nozzle         |
| 5. Air filter                               | 11. ESD-lead connection                         |
| 6. Handle                                   | 12. Tool stand (wich can be rotated and fixed). |

**Operating condition**

- As required, push-fit appropriate **nozzle (9)**.
- Connect tool to the mains.
- The air flow is steplessly adjustable by use of the black **potentiometer (4)**.
- The hot air temperature is steplessly adjustable by use of the red **potentiometer (3)**.
- If required, earth the tool via the ESD-lead connection.
- **Switch on (2)** and allow to warm up for about 5 min.

**Operation**

- The Leister Company, as well as the Service Centres, offer free training courses in all areas of application (see page 1).

**Change of nozzles**

- Before changing nozzles, allow the tool to cool down, or use only combination pliers.
- Do not touch hot **nozzle (9)** and make sure to put it only on a heat resistant surface, because of the **fire hazard**.
- The nozzles are easily pushed onto the tapered **element housing (8)** and are then secured by fastening the **screw on the clamp (10)**.
- Only Leister nozzles should be used.

## MAINTENANCE

- The welding tool's **airfilter (5)** should be cleaned with a brush if necessary.
- A wire brush should be used for cleaning the **welding nozzle (9)**.

## ACCESSORIES

- Use only LEISTER accessories.

## SERVICE AND REPAIRS

- The carbon brushes of the motor have to be checked by your Service Centre after about 700 hours running time.
- Repairs should only be carried out by authorised **LEISTER Service Centres**. They guarantee a specialised and reliable **Repair Service within 24 hours** using original spare parts lists.

## GUARANTEE AND LIABILITY

- Guarantee and liability are in accordance with the guarantee certificate as well as with the currently valid general business and sales conditions.
- LEISTER Process Technologies rejects any guarantee claims for tools which are not in their original condition. The tools must never be altered or changed.

**Technical data and specifications are subject to change without prior notice.**

Authorized Service Center: STAR Process Heat Systems - 877-782-7747