

# LEISTER Hotwind S

## Hot-Air Blower



Please read operating instructions carefully before use and keep for further reference.

### APPLICATION

- The LEISTER Hotwind S is suitable for continuous operation. The blower can be used as a hand or bench tool or can be built into machines, installations and appliances.
- **Drying and heating processes** of various types.
- **Heating** conveyor ovens or heat tunnels.
- **Defrosting** frozen water pipes.
- **Speeding up** mixing processes and **dissolving** foams which can arise during mixing and filling.
- **Sterilizing** of packaging materials such as bottles, corks and containers.
- **Smoothing** the coating on pills, putting a shine on chocolates and cosmetic articles.
- **Activating and loosening** solvent free adhesives and melt adhesives.
- **Separating and fusing** of synthetic fibres and fabrics.
- **Shrinking** of heat-shrink sleeves, films, tapes, solder sleeves and moulded parts.
- **Soldering** SMD and thru-hole components.
- **Soldering** copper pipes, solder joints and metal foils.
- **Welding** thermoplastic materials.
- **Removing** plastic mould flash and putting a **shine** on plastic surfaces.
- **Igniting** wood shavings, paper, coal or straw in furnaces.





## WARNING



**Danger to life** when opening the tool, as live components and connections are exposed. Therefore, before opening it, disconnect all poles from the mains.



Incorrect use of hot air blowers can cause **fire and explosion hazard**, especially near combustible materials and explosive gases.



Do not touch the element housing and nozzle when they are hot as they can cause **burns**. Let the tool cool down. Do not point hot air flow in the direction of people or animals.



## CAUTION



The **voltage rating** stated on the tool must correspond to the line/mains voltage.  
EN 61000-3-11;  $Z_{max} = 0.047 \Omega + j 0.029 \Omega$ . If necessary, consultate supply authority.



For personal protection on building sites we **strongly recommend** the tool be connected to a **GFCI** (Ground Fault Circuit Interrupter) or a **RCCB** (Residual Current Circuit Breaker).



The tool must be operated **with supervision**. Warmth can reach combustible materials, which are out of sight.



Protect tool from **damp** and **wet**.

## APPROVAL MARK



The tool is **CCA** certified (CENELEC Certification Agreement).

## TECHNICAL DATA

## Electrical safety Double insulated

		230	230	380–440	120	100
Voltage	V~	50/60	50/60	50/60	50/60	50/60
Frequency	Hz	3700	3100	4000–5400	2300	2000
Power consumption	W	650	800	620	560	450
Temperature	°C	550	350	600	450	450
Air flow (20 °C)	l/min.	200	200	200	200	200
Air pressure	mbar	53	53	53	53	53
Emission level	$L_{pA}$ (dB)	2.9	3.2	3.2	3.2	3.2
Weight	kg	310×72×99	350×172×99			
Size	mm					

1 mbar = 100 Pa

Description of tool

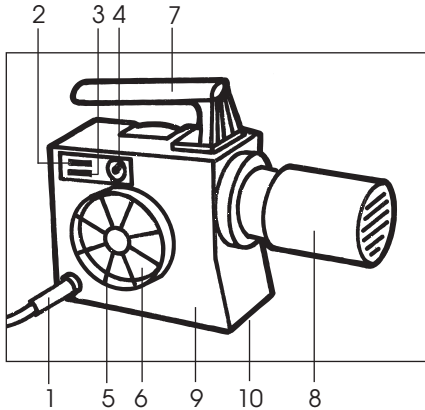

1. Power supply cord
2. On/off switch stage 0 = off  
stage 1 = on (cold air)
3. Switch for heater stage 2 = off  
stage 3 = on
4. Potentiometer for temperature control
5. Air slide
6. Air intake
7. Removable handle
8. Element housing with protective tube
9. Plastic housing
10. Six M5 drilled and tapped holes for fixing into installation

Installation

- When fixing, the **drilled and tapped holes M5 (9)** on the bottom side of the housing should be used.
- If necessary, attach **handle (6)** by push-fitting sideways.
- When installing the tool, make sure that
  - only cold air is sucked in
  - no air is sucked in from the hot-air tool
  - no (warm air) back pressure develops
  - the hot-air tool is not in direct line of the hot-air flow from another hot-air tool.
- For use in a dusty environment the tool should be fitted with a LEISTER stainless steel filter on the **air intake (5)**. Where a particularly critical dust problem exists (eg metal, electrically charged or damp dust) special filters must be used to avoid short circuiting the tool.
- Protect the tool from vibration and shock.

- Installation dimensions in mm

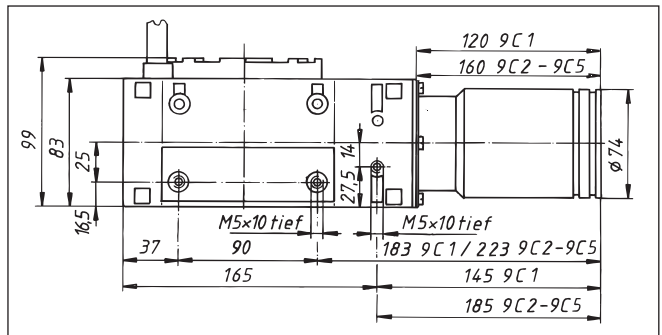
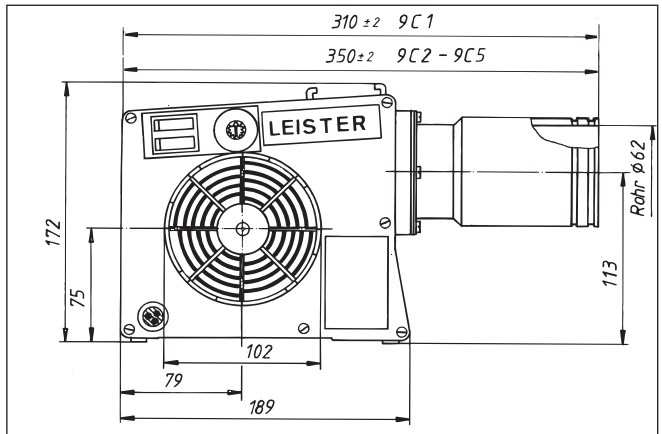

## Operation

- Connect tool to the mains.
- As required, push-fit appropriate nozzle or reflector.
- Set **on/off switch (2)** to stage 1.
- Reduce air flow as required by using the **air slide (5)**.
- Adjust hot-air temperature by using the **potentiometer (4)**.
- Set **heater switch (3)** to stage 3 and allow to warm up for about 5 min. Make sure that the hot-air can flow freely, as back pressure can develop and possibly damage the tool (**fire hazard**).
- LEISTER Process Technologies as well as the Service Centres offer free training courses for all applications (see page 1).
- After use, turn **heater switch (3)** to stage 2, and **on/off switch (2)** to stage 1 and let the tool cool down (preventing warm air back pressure).

## CAUTION:

- ★ *When fixing the tool into an installation, the mains connection must have a suitable device for disconnect all poles from the mains with a 3 mm distance between contacts.*

## SPECIAL FEATURES

- Temperature adjustment with external potentiometer.
- Temperature control signal with external control voltage (VDC).
- Temperature control with additional LEISTER cascade controller (KSR) should only be fitted and adjusted by the LEISTER Process Technologies.

## ACCESSORIES

- Only LEISTER nozzles and reflectors must be used.

## WARTUNG

- The tool's **air intake (6)** should be cleaned with a brush if necessary.
- Check **power supply cord (1)** and plug for any possible electrical or mechanical damages.

## SERVICE AND REPAIR

- Repairs have to be carried out by authorised **LEISTER Service Centres** only. They guarantee a specialized and reliable **repair service within 24 hours** using original LEISTER spare parts.

## GUARANTEE AND LIABILITY

- Guarantee and liability are in accordance with the guarantee certificate as well as with the currently valid general business and sales conditions.
- LEISTER Process Technologies rejects any guarantee claims for tools which are not in their original condition. The tools must never be altered or changed.

**Technical data and specifications are subject to change without prior notice.**

Authorized Service Center: STAR Process Heat Systems, NJ - 877-782-7747